

SPRING SOCKETS

FF

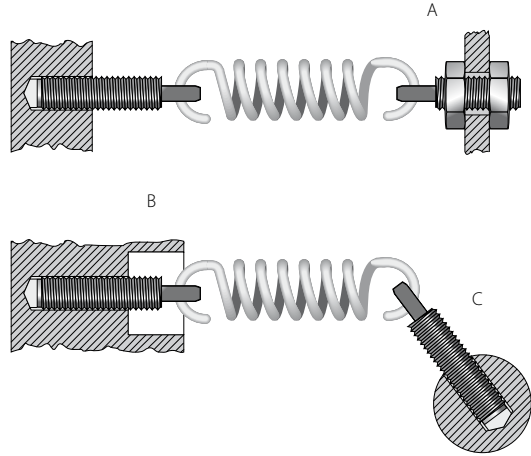

Fitting example

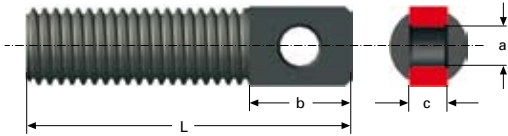

Spring sockets may be used for the mounting of an extension spring. You can easily adjust the spring force by screwing the socket in or out. Spring sockets are available as standard in seven dimensions; one length of each.

If the spring socket is mounted as shown in fig. A, the spring force can easily be adjusted without disengaging the spring. Where space is limited, the spring socket can be used as shown in fig. B. Fig. C shows a spring socket used as a lever.

All dimensions are in mm

- L = Total length
- a = Hole diameter
- b = Mounting loop length
- c = Mounting loop thickness
- D_t = For maximum wire diameter

Material: SS 1650

Finish: Galvanised and black chromated

Thread	L	a	b	c	D_t	Cat. no.
M3	12	1,2	3,2	1,7	1,0	4658
M4	18	1,6	4,5	2	1,5	4659
M5	20	2,2	5,5	2,5	2,0	8958
M6	25	2,7	6,7	3	2,5	4660
M8	35	3,7	9	4	3,5	4661
M10	45	5,2	11	5	5	4662
M14	55	6,4	16	7	6	4663