

# CURVED SPRING WASHERS

DIN 137



Curved spring washers are primarily used in screwed joint reinforcements where a lower locking force is required. These washers can also be used to eliminate axial play. Type A is recommended for screws with rounded heads and type B for screws with hexagon heads.

All dimensions are in mm

$D_i$  = Inner diameter

$D_y$  = Outer diameter

$t$  = Material thickness

$h$  = Unloaded length

Material: Spring steel CK 67

Finish: Untreated

## TYPE A

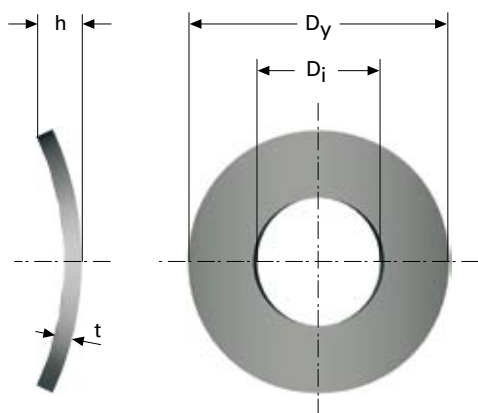

## TYPE B

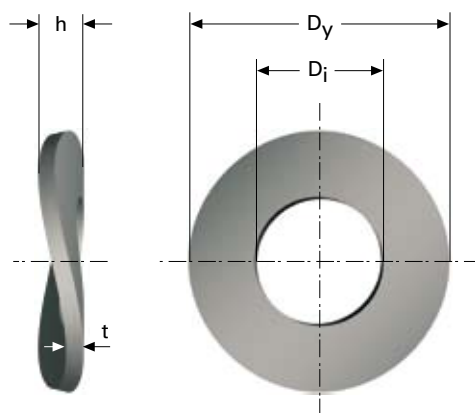

Bolt Ø	$D_i$ H14	$D_y$ js16	$t$	$h$ min.	$h$ max	Cat. no
2	2,2	4,5	0,3	0,5	1	0862
2,3	2,5	5	0,3	0,5	1	0863
2,6	2,8	5,5	0,3	0,55	1,1	0864
3	3,2	6	0,4	0,65	1,3	0865
3,5	3,7	7	0,4	0,7	1,4	0866
4	4,3	8	0,5	0,8	1,6	0867
5	5,3	10	0,5	0,9	1,8	0868
6	6,4	11	0,5	1,1	2,2	0869
7	7,4	12	0,5	1,4	2,6	0870
8	8,4	15	0,5	1,7	3,4	0871
10	10,5	18	0,8	2	4	0872
12	13	24	1,2	2,5	4,5	0873
16	16,5	30	1,5	3	5	0874

Bolt Ø	$D_i$ H14	$D_y$ js16	$t$	$h$ min.	$h$ max	Cat. no
4	4,3	9	0,5	1	2	0875
5	5,3	11	0,5	1,1	2,2	0876
6	6,4	12	0,5	1,3	2,6	0877
8	8,4	15	0,8	1,5	3	0878
10	10,5	21	1	2,1	4,2	0879
12	13	24	1,2	2,5	5	0880
14	15	28	1,6	3	6	0881
16	17	30	1,6	3,2	6,4	0882